

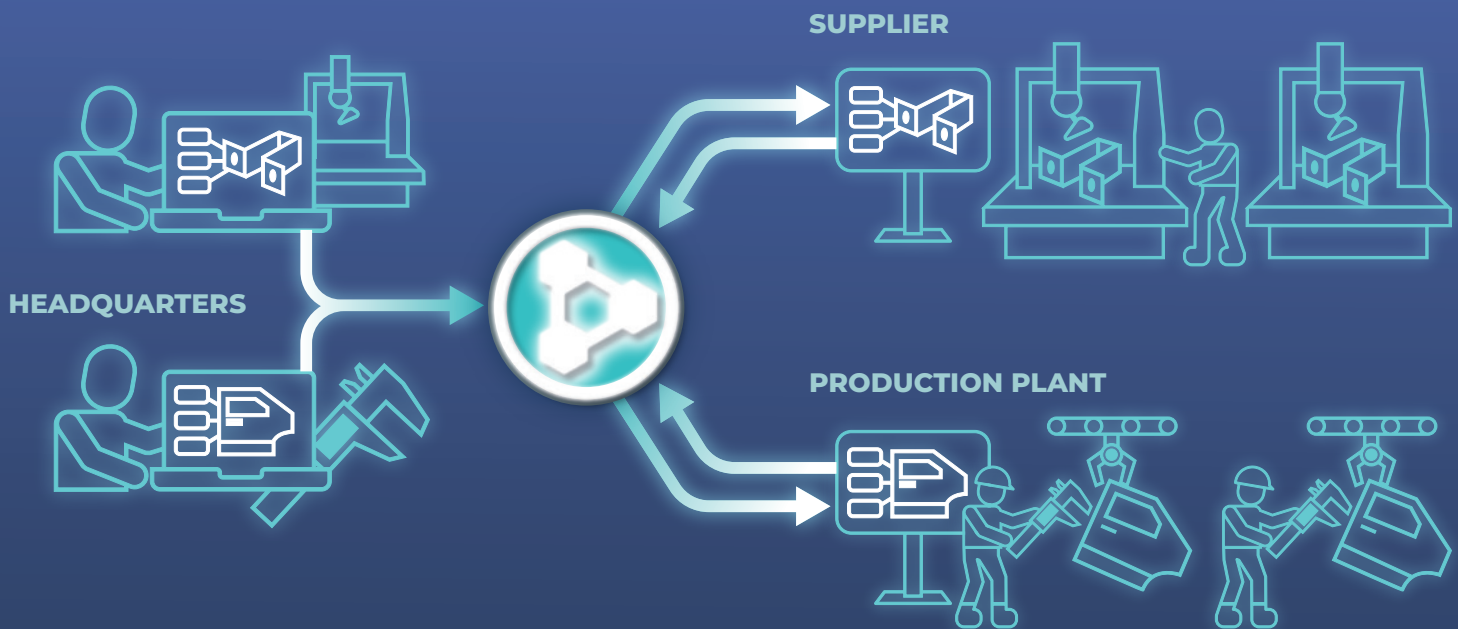

What's new in PolyWorks® 2026

Metrology Process



Trustworthy Measurements from Multisite Inspections

Building on our smart inspection template technology that enables packaging a measurement plan with standardized instructions, PolyWorks|Inspector™ 2026 now lets you control the downstream experience by linking a piece template to a tailored interface.

► SIMPLIFY MULTISITE INSPECTIONS

Whether at your own site or at a supplier's, tailored interfaces show only what you need for inspection, helping metrologists learn quickly and perform measurement efficiently.

► PREVENT ERRORS

Hide unnecessary tools that could compromise measurement accuracy to ensure process integrity.

► ACHIEVE REPEATABLE AND REPRODUCIBLE RESULTS

Standardized templates paired with tailored interfaces ensure consistent measurement results across plants and suppliers.

Gain greater confidence in your measurement results—no matter which site they come from—thanks to a standardized process that guarantees reliability.

innovmetric

Identify Dimensional Requirements and Create Inspection Projects

Standardized expertise, simplified experience

Leverage visual layouts in PolyWorks|Inspector 2026 to make the most of your expertise and elevate your downstream experience.

▶ BOOST EFFICIENCY WITH OPTIMIZED INTERFACES

Visual layouts hide unnecessary tools and organize elements to accelerate measurement execution.

▶ AUTOMATE REPETITIVE OPERATIONS

Embedded macros streamline repetitive steps, reducing manual effort and minimizing errors.

▶ CENTRALIZE EXPERTISE SHARING

Experts can manage, update, and distribute layouts digitally to promote consistent practices across teams.

Work smarter and faster with standardized inspection processes that boost productivity while ensuring consistency enterprisewide.

Integrate CAD intelligence, accelerate your inspection workflows

To guarantee every part meets its specifications, Quality teams must connect design and manufacturing intent with measurement processes. With PolyWorks|Inspector 2026, you can leverage the power of native CAD models to speed up your inspection workflows.

▶ CREATE CONTROL VIEWS MORE EASILY

Import 3D CAD views from third-party software platforms (CATIA, NX, Creo) into PolyWorks|Inspector to seamlessly create control views.

▶ UPDATE PIECE TEMPLATES AUTOMATICALLY

Replace imported assemblies with their latest revision to keep piece templates up to date.

Accelerate the creation of detailed 3D inspection reports and ensure they all reflect their latest CAD revision.

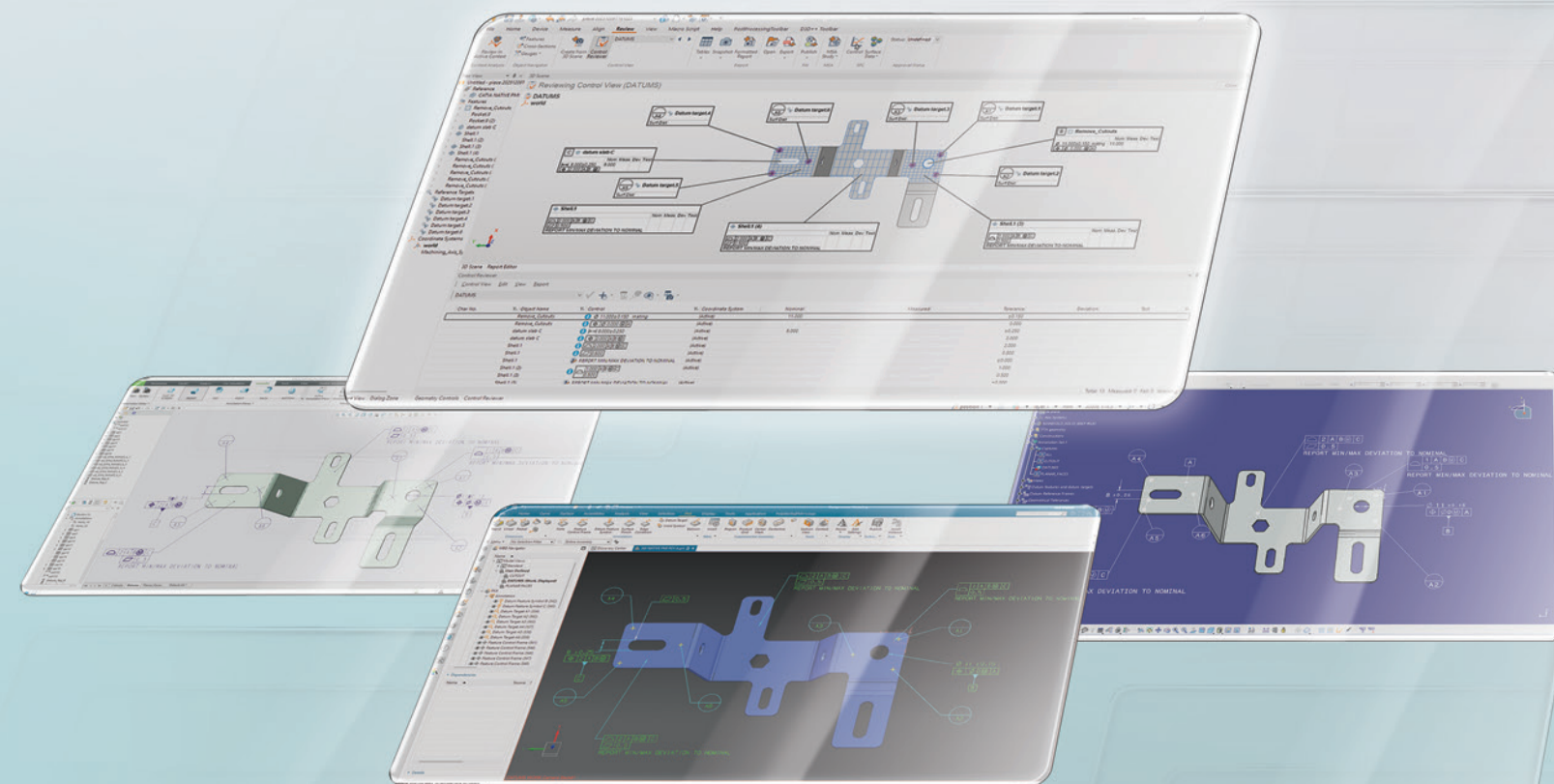

Measure Pieces

Expanded PolyWorks|Inspector universality

PolyWorks|Inspector 2026 further enhances the flexibility and usability of its universal platform, delivering consistent, advanced inspection capabilities across CT and handheld scanners, shop-floor hardware, as well as CNC CMMs.

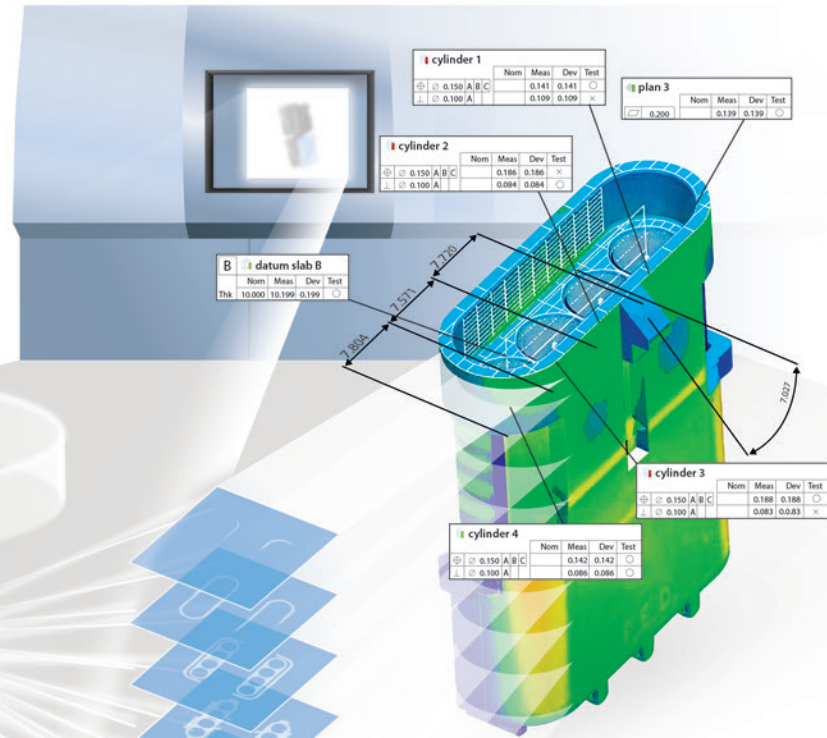

NEW CT SCANNING MODULE

- ▶ Leverage GPU-accelerated meshing for enhanced speed and precision.
- ▶ Automatically extract multiple pieces from a single CT scan.

Automate CT-based multipiece inspections in production environments.

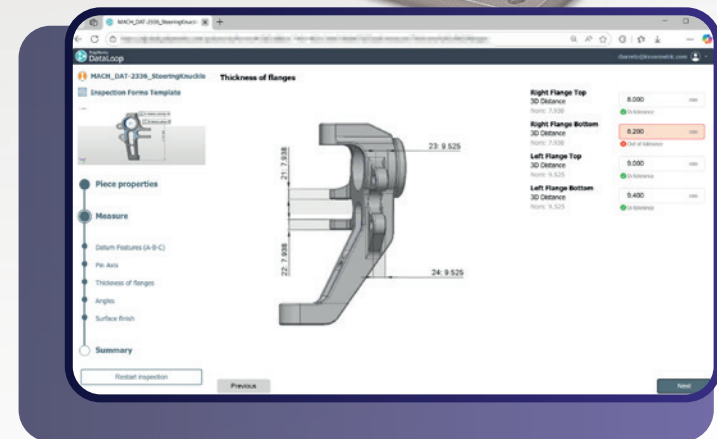

MANUAL DATA-COLLECTION DEVICES

- ▶ Enter measured values from handheld gauges and visual checks using the new web-based inspection forms.
- ▶ Upload measurements directly to PolyWorks|DataLoop™ for seamless downstream processing.

Collect and consolidate shop-floor data from a wider range of devices.

HANDHELD MULTILINE 3D SCANNERS

- ▶ Display scan data from handheld multiline scanners in real time within PolyWorks|Inspector.
- ▶ Access the complete inspection toolbox during scan data acquisition, including automatic scan-to-CAD alignment as well as surface and feature scanning guidance.

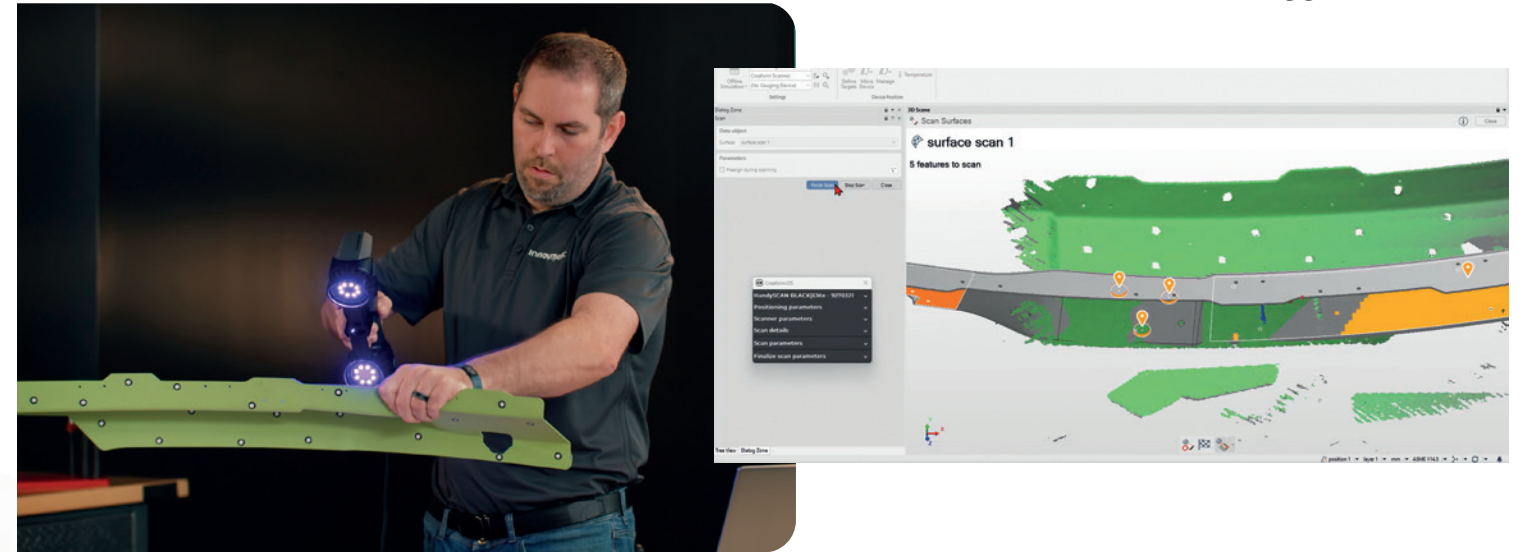

Eliminate manual transfers and perform inspections without having to switch software platforms.

CNC CMMs

- ▶ Perform go-to-positioning of 5-axis probe heads natively to help reduce cycle time.
- ▶ Configure CNC probing using the new **Head touch** option for improved accuracy and efficiency.
- ▶ Prevent costly errors with collision analysis, which now supports 5-axis probe heads for go-to-positioning and head touch measurements.
- ▶ Take advantage of the new plug-in for Deva CNC CMM controllers.

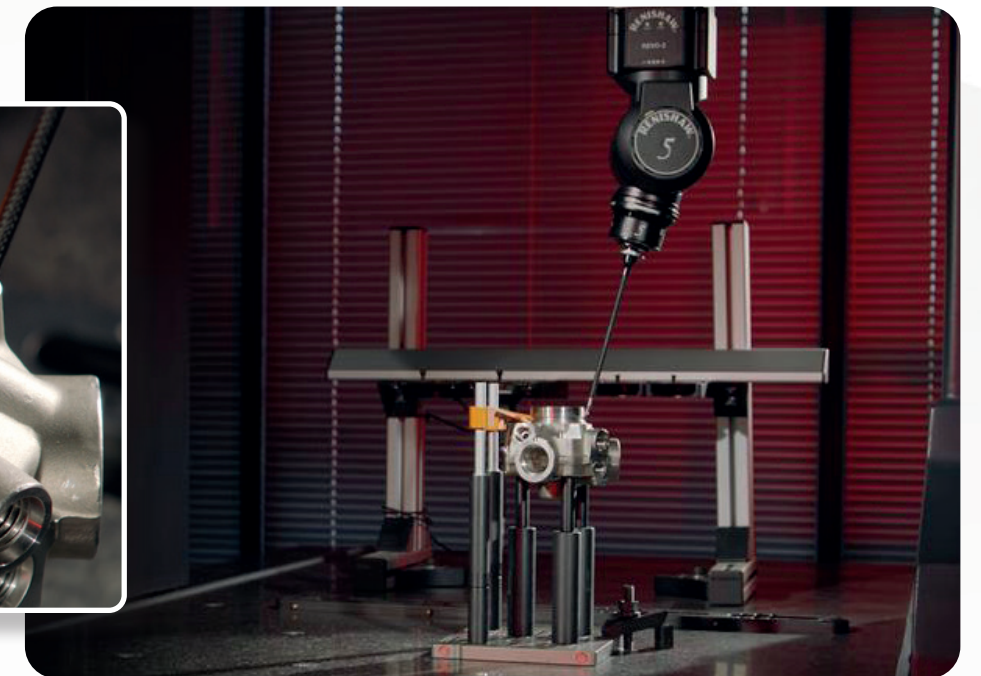

Confidently harness the full potential of 5-axis probe heads.

Communicate, Review, and Analyze Measurement Results

Streamlined reporting, from raw data to actionable insights

PolyWorks 2026 introduces enhancements that simplify how team members communicate dimensional inspection results, anticipate issues, and present insights in formats everyone understands, whether on the shop floor or across global sites.

- ▶ **REVIEW EDITED DIMENSIONAL CONTROLS**
PolyWorks|Inspector enables users to manually edit or overwrite measured values, particularly useful for CAD-less workflows or gauge-based measurements. With version 2026, you can now identify the edited values directly within report tables or via the PolyWorks|DataLoop API.
- ▶ **ANTICIPATE DIMENSIONAL FAILURES**
Trend chart widgets now include forecast lines predicting near-future dimensional values.
- ▶ **VISUALIZE CRITICAL CONTROLS INSTANTLY**
Add dynamic control view-based widgets to dashboards for quick visibility of key dimensions.
- ▶ **ENSURE ANNOTATION CONSISTENCY**
The PolyWorks|DataLoop Web Interface now displays single-piece annotations and multipiece SPC annotations, mirroring PolyWorks|Inspector.
- ▶ **STANDARDIZE EXCEL REPORTING**
Leverage control views in your predefined PolyWorks|ReportLoop™ templates to maintain uniform layouts across projects.

Quality control teams can provide actionable insights that empower colleagues to make data-driven decisions.

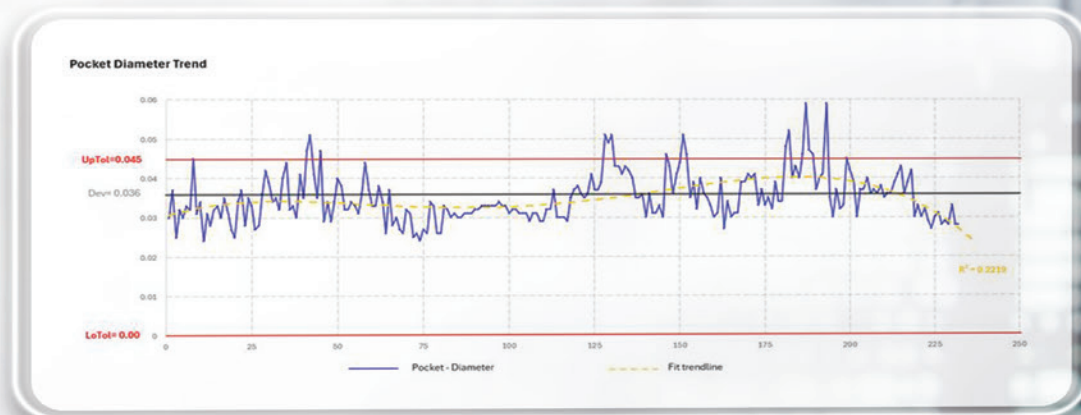

The PolyWorks Experience

The new MyPolyWorks AI assistant

Your time matters. And with PolyWorks 2026, you'll never have to wait for answers. Our new AI assistant offers instant, reliable technical guidance—whether you're troubleshooting a workflow or simply exploring best practices.

- ▶ **BENEFIT FROM 24/7 TECHNICAL ASSISTANCE**
Get clear and precise responses from our AI assistant, anytime, anywhere.
- ▶ **EXPERIENCE LOCALIZED SUPPORT**
Communicate in your preferred language for a smooth, personalized experience.
- ▶ **RELY ON TRUSTWORTHY SOURCES**
Receive answers based on official documentation, video tutorials, and support cases, with hyperlinks leading to additional information.
- ▶ **LEVERAGE HUMAN EXPERTISE ON DEMAND**
Prefer talking to us? Our technical support experts are just a call away, always available to help.

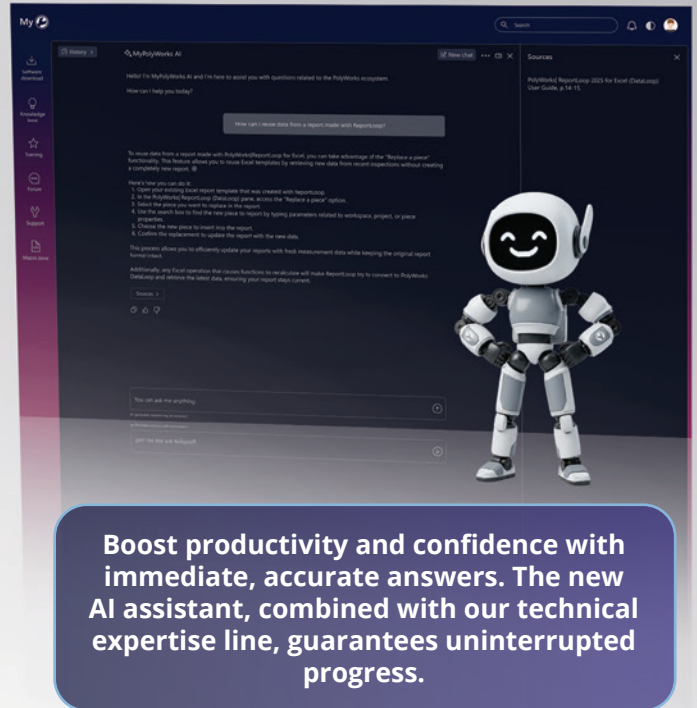

Your screen, your choice: introducing dark mode

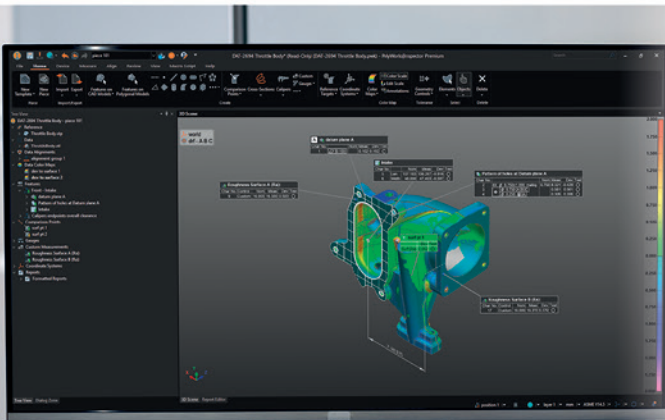

- ▶ **CUSTOMIZE YOUR EXPERIENCE**
Switch between light and dark mode to match your preferred working style.
- ▶ **REDUCE EYE STRAIN**
Use dark mode to minimize glare and optimize comfort during long inspection sessions or in low-light conditions.

Stay focused and reduce eye strain during extended sessions with an interface that can be easily tailored to your environment or preferences.

© 2026 InnovMetric Software Inc. All rights reserved. PolyWorks® is a registered trademark of InnovMetric Software Inc. PolyWorks|Inspector™, PolyWorks|DataLoop™, and PolyWorks|ReportLoop™ are trademarks of InnovMetric Software Inc.

innovmetric

InnovMetric Software Inc.
2014 Cyrille-Duquet, Suite 310, Québec QC G1N 4N6 Canada
Contact us: 1-418-688-2061 | 1-888-688-2061 info@innovmetric.com
polyworks.com